



# Mark Scheme (Result)

October 2020

Pearson Edexcel GCE In A level Further  
Mathematics  
Paper 9FM0/3C

## **Edexcel and BTEC Qualifications**

Edexcel and BTEC qualifications are awarded by Pearson, the UK's largest awarding body. We provide a wide range of qualifications including academic, vocational, occupational and specific programmes for employers. For further information visit our qualifications websites at [www.edexcel.com](http://www.edexcel.com) or [www.btec.co.uk](http://www.btec.co.uk). Alternatively, you can get in touch with us using the details on our contact us page at [www.edexcel.com/contactus](http://www.edexcel.com/contactus).

## **Pearson: helping people progress, everywhere**

Pearson aspires to be the world's leading learning company. Our aim is to help everyone progress in their lives through education. We believe in every kind of learning, for all kinds of people, wherever they are in the world. We've been involved in education for over 150 years, and by working across 70 countries, in 100 languages, we have built an international reputation for our commitment to high standards and raising achievement through innovation in education. Find out more about how we can help you and your students at: [www.pearson.com/uk](http://www.pearson.com/uk)

October 2020

Publications Code 9FM0\_3C\_2010\_MS

All the material in this publication is copyright

© Pearson Education Ltd 2020

## General Marking Guidance

- All candidates must receive the same treatment. Examiners must mark the first candidate in exactly the same way as they mark the last.
- Mark schemes should be applied positively. Candidates must be rewarded for what they have shown they can do rather than penalised for omissions.
- Examiners should mark according to the mark scheme not according to their perception of where the grade boundaries may lie.
- There is no ceiling on achievement. All marks on the mark scheme should be used appropriately.
- All the marks on the mark scheme are designed to be awarded. Examiners should always award full marks if deserved, i.e. if the answer matches the mark scheme. Examiners should also be prepared to award zero marks if the candidate's response is not worthy of credit according to the mark scheme.
- Where some judgement is required, mark schemes will provide the principles by which marks will be awarded and exemplification may be limited.
- When examiners are in doubt regarding the application of the mark scheme to a candidate's response, the team leader must be consulted.
- Crossed out work should be marked UNLESS the candidate has replaced it with an alternative response.

# EDEXCEL GCE MATHEMATICS

## General Instructions for Marking

1. The total number of marks for the paper is 75.
2. The Edexcel Mathematics mark schemes use the following types of marks:
  - **M** marks: method marks are awarded for 'knowing a method and attempting to apply it', unless otherwise indicated.
  - **A** marks: Accuracy marks can only be awarded if the relevant method (M) marks have been earned.
  - **B** marks are unconditional accuracy marks (independent of M marks)
  - Marks should not be subdivided.
3. Abbreviations

These are some of the traditional marking abbreviations that will appear in the mark schemes.

- bod – benefit of doubt
  - ft – follow through
  - the symbol  $\surd$  will be used for correct ft
  - cao – correct answer only
  - cso - correct solution only. There must be no errors in this part of the question to obtain this mark
  - isw – ignore subsequent working
  - awrt – answers which round to
  - SC: special case
  - oe – or equivalent (and appropriate)
  - dep – dependent
  - indep – independent
  - dp decimal places
  - sf significant figures
  - \* The answer is printed on the paper
  - $\square$  The second mark is dependent on gaining the first mark
4. All A marks are 'correct answer only' (cao.), unless shown, for example, as A1 ft to indicate that previous wrong working is to be followed through. After a misread however, the subsequent A marks affected are treated as A ft, but manifestly absurd answers should never be awarded A marks.

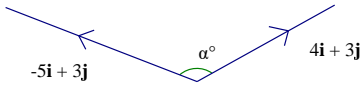
Question	Scheme	Marks	AOs
<b>1a</b>	Impulse-momentum equation	M1	3.1a
	$\mathbf{J} = 0.5(-\mathbf{i} + 6\mathbf{j} - 4\mathbf{i} - 3\mathbf{j})$ $(\mathbf{J} = 0.5(-5\mathbf{i} + 3\mathbf{j}))$	A1	1.1b
	Find magnitude of $\mathbf{J}$ :	M1	1.1b
	$ \mathbf{J} ^2 = \frac{1}{4}(25+9), \quad  \mathbf{J}  = \frac{\sqrt{34}}{2} \text{ (N s)}$	A1	1.1b
		(4)	
<b>1b</b>			
	Correct use of trig	M1	3.1a
	$\alpha^\circ = 180^\circ - \tan^{-1} \frac{3}{4} - \tan^{-1} \frac{3}{5}$ or $\alpha^\circ = \tan^{-1} \frac{4}{3} + \tan^{-1} \frac{5}{3}$	A1ft	1.1b
	$\alpha = 112$	A1	1.1b
		(3)	
<b>1balt</b>	Use scalar product of $\mu\mathbf{J}$ and $4\mathbf{i} + 3\mathbf{j}$ to find the angle	M1	3.1a
	$\cos \alpha^\circ = \frac{-20+9}{\sqrt{34} \times 5}$	A1ft	1.1b
	$\alpha = 112$	A1	1.1b
		(3)	
<b>1balt</b>	Use of cosine rule in triangle of momenta or equivalent	M1	3.1a
	$\alpha^\circ = 180^\circ - \cos^{-1} \left( \frac{34 + 25 - 37}{2 \times 5 \times \sqrt{34}} \right)$	A1ft	1.1b
	$\alpha = 112$	A1	1.1b
		(3)	
<b>(7 marks)</b>			
<b>Notes:</b>			
<b>(a)M1</b>	Dimensionally correct. Must be subtracting, but condone subtracting in the wrong order.		
<b>A1</b>	Correct unsimplified equation		
<b>M1</b>	Correct application of Pythagoras to find the magnitude. (from $\pm\mathbf{J}$ )		
<b>A1</b>	2.9 or better (2.9154....) (from $\pm\mathbf{J}$ )		

<b>(b)M1</b>	Correct use of trig to find a relevant angle using $4\mathbf{i} + 3\mathbf{j}$ and their <b>J</b> i.e. $\alpha^\circ$ or $180^\circ - \alpha^\circ$ Allow $\frac{ \mathbf{a}\cdot\mathbf{b} }{ \mathbf{a}  \mathbf{b} }$
<b>A1ft</b>	Correct unsimplified expression for the required angle. Follow their <b>J</b> A0 for $\frac{ \mathbf{a}\cdot\mathbf{b} }{ \mathbf{a}  \mathbf{b} }$ Do not ISW
<b>A1</b>	110 or better (112.166.....) or accept $247.8\dots^\circ$

Question	Scheme	Marks	AOs
<b>2(a)</b>	Equation of motion: $F - (900 + 9 \times 25) = 1200a$	M1	3.3
	Use of $25000 = F \times 25$	M1	3.4
	$\frac{25000}{25} - (900 + 225) = 1200a$	A1	1.1b
	$a = -\frac{5}{48}$ deceleration = $\frac{5}{48}$ (= 0.10416..) ( $\text{ms}^{-2}$ )	A1	1.1b
		(4)	
<b>(b)</b>	Equation of motion:	M1	3.3
	$\frac{25000}{V} - 1200g \sin \theta - (900 + 9V) = 0$	A1 A1	1.1b 1.1b
	Form quadratic and solve for V:	M1	1.1b
	$(9V^2 + 1488V - 25000 = 0)$ $V = 15.4(15)$	A1	1.1b
		(5)	
<b>(9 marks)</b>			
<b>Notes:</b>			
<b>(a)M1</b>	Dimensionally correct. Condone sign errors		
<b>M1</b>	Correct use of $P = Fv$ . Allow in (b) if not seen in (a).		
<b>A1</b>	Correct unsimplified equation		
<b>A1</b>	0.10 or better. Final answer must be positive.		
<b>(b)M1</b>	Need all terms. Dimensionally correct. Condone sign errors		
<b>A1</b>	Unsimplified equation with at most one error		
<b>A1</b>	Correct unsimplified equation		
<b>M1</b>	Complete method to solve for V		
<b>A1</b>	Correct to 2 sf or 3 sf		

Question	Scheme	Marks	AOs
<b>3(a)</b>	Taking left to right as positive, 		
	CLM:	M1	3.1a
	$6mu + 4mu (= 10mu) = 3mv + 4mw \quad (10u = 3v + 4w)$	A1	1.1b
	Impact Law:	M1	3.4
	$w - v = e(2u - u) (= eu)$	A1	1.1b
	Solve for $v$ or $w$	M1	2.1
	$w = \frac{u}{7}(10 + 3e)$	A1	1.1b
	$v = \frac{u}{7}(10 - 4e)$	A1	1.1b
	$0 \leq e \leq 1 \Rightarrow 10 + 3e > 0$ and $10 - 4e > 0$ hence both particles still travelling in the original direction. *	A1*	2.2a
		<b>(8)</b>	
<b>(b)</b>	CLM: $4mw = 4mx + 2my \quad (2w = 2x + y)$	M1	3.1a
	Impact: $y - x = ew$	M1	3.4
	$\Rightarrow w(2 - e) = 3x, \quad x = \frac{u}{21}(10 + 3e)(2 - e)$	M1	1.1b
	Consider $v - x$ i.e. $\frac{u}{7}(10 - 4e) - \frac{u}{21}(10 + 3e)(2 - e)$ $(3e^2 - 8e + 10)$	M1	2.1
	Show that $v - x > 0 \forall e$	M1	1.1b
	Complete correct argument and conclusion *	A1*	2.2a
		<b>(6)</b>	
<b>(14 marks)</b>			
<b>Notes:</b>			
<b>(a)M1</b>	All terms required. Condone sign errors.		
<b>A1</b>	Correct unsimplified equation		

<b>M1</b>	Law used correctly. Condone sign errors
<b>A1</b>	Correct unsimplified equation
<b>M1</b>	Use their correctly formed equations to solve for $v$ or $w$
<b>A1</b>	Either velocity correct
<b>A1</b>	Both velocities correct
<b>A1*</b>	Use possible values of $e$ to justify given result from correct working.
<b>(b)M1</b>	All terms required. Condone sign errors
<b>M1</b>	Correct use of impact law. Condone sign errors
<b>M1</b>	Use their correctly formed equations to find velocity of $B$ ( $x$ )
<b>M1</b>	Form relevant difference for a second collision
<b>M1</b>	Complete correct method (e.g. differentiation or completing the square or discriminant ) to determine when inequality is true
<b>A1*</b>	Reach correct conclusion from correct work.

Question	Scheme	Marks	AOs
<b>4(a)</b>	Use of $\mathbf{I} = m\mathbf{v} - m\mathbf{u}$ or $\mathbf{v} - \mathbf{u}$	M1	2.1
	$\mathbf{I} = 0.5((\mathbf{i} + 6\mathbf{j}) - (7\mathbf{i} + 2\mathbf{j})) = (-3\mathbf{i} + 2\mathbf{j})$	A1	1.1b
	Use of scalar product $(-3\mathbf{i} + 2\mathbf{j}) \cdot (2\mathbf{i} + 3\mathbf{j}) = -6 + 6 = 0$	M1	1.1b
	Hence impulse perpendicular to $(2\mathbf{i} + 3\mathbf{j})$ , so $AB$ must be parallel to $(2\mathbf{i} + 3\mathbf{j})$ . *	A1*	2.2a
		(4)	
<b>4(a) alt</b>	Components of velocities parallel to $(2\mathbf{i} + 3\mathbf{j})$ :	M1	2.1
	$\left(\frac{1}{\sqrt{13}}\right)(7\mathbf{i} + 2\mathbf{j}) \cdot (2\mathbf{i} + 3\mathbf{j}) = \left(\frac{1}{\sqrt{13}}\right)(14 + 6)$ $\left(\frac{1}{\sqrt{13}}\right)(\mathbf{i} + 6\mathbf{j}) \cdot (2\mathbf{i} + 3\mathbf{j}) = \left(\frac{1}{\sqrt{13}}\right)(2 + 18)$	A1	1.1b
	Simplify and compare values	M1	1.1b
	Hence component of velocity parallel to $(2\mathbf{i} + 3\mathbf{j})$ is unchanged, so $AB$ must be parallel to $(2\mathbf{i} + 3\mathbf{j})$ . *	A1*	2.2a
		(4)	
<b>4(a) alt</b>	Use conservation of velocity parallel to $a\mathbf{i} + b\mathbf{j}$	M1	2.1
	$(7\mathbf{i} + 2\mathbf{j}) \cdot (a\mathbf{i} + b\mathbf{j}) = (\mathbf{i} + 6\mathbf{j}) \cdot (a\mathbf{i} + b\mathbf{j})$ $(\Rightarrow 7a + 2b = a + 6b)$	A1	1.1b
	Find ratio of $a$ and $b$ to obtain direction: $\left(b = \frac{2}{3}a\right)$	M1	1.1b
	Hence $AB$ must be parallel to $(2\mathbf{i} + 3\mathbf{j})$ . *	A1*	2.2a
		(4)	
<b>4(b)</b>	Use scalar product to find components of velocities perpendicular to the wall	M1	3.1b
	$\left(\frac{1}{\sqrt{13}}\right)(-3\mathbf{i} + 2\mathbf{j})(7\mathbf{i} + 2\mathbf{j}) = \left(\frac{1}{\sqrt{13}}\right)(-21 + 4) \left(= \frac{-17}{\sqrt{13}}\right)$ $\left(\frac{1}{\sqrt{13}}\right)(-3\mathbf{i} + 2\mathbf{j})(\mathbf{i} + 6\mathbf{j}) = \left(\frac{1}{\sqrt{13}}\right)(-3 + 12) \left(= \frac{9}{\sqrt{13}}\right)$	A1 A1	1.1b 1.1b
	Use of impact law	M1	3.4
	$e = \frac{9}{17}$	A1	1.1b

		(5)	
<b>(9 marks)</b>			
<b>Notes:</b>			
<b>(a)M1</b>	Must be finding the difference between two momenta or two velocities		
<b>A1</b>	Correct unsimplified equation for the impulse or for change in velocity		
<b>M1</b>	Use of scalar product or equivalent. In the alt method allow full marks if $\sqrt{13}$ not used.		
<b>A1*</b>	Reach given conclusion from correct working		
	<p>If working with angles, score  M1 for correct method to find components parallel to the wall  A1 for <math>\sqrt{53} \cos 40.36..^\circ</math> and <math>\sqrt{37} \cos 24.23..^\circ</math>  M1 for comparing the two values  A0 because the work has involved decimal approximations (since working towards an exact given answer).</p> <p>Alternative: Could use <math>e \tan 24.2..^\circ = \tan 40.36..^\circ</math></p>		
<b>(b)M1</b>	Condone if not using a unit vector		
<b>A1</b>	One correct value		
<b>A1</b>	Second correct values		
	If working with angles, score M1A1A1 for $\sqrt{53} \sin 40.36..^\circ$ and $\sqrt{37} \sin 24.23...^\circ$		
<b>M1</b>	Use their components the right way round in the impact law. Condone sign error.		
<b>A1</b>	0.53 or better (0.52941.....)		

Question	Scheme	Marks	AOs
<b>5(a)</b>			
	Components perpendicular to the line of centres after the collision: $\mathbf{v}_{Pj} = 2\mathbf{j} \text{ (ms}^{-1}\text{)}, \quad \mathbf{v}_{Qj} = \mathbf{j} \text{ (ms}^{-1}\text{)}$	B1	3.4
	Kinetic energy:	M1	3.1a
	$\frac{1}{2} \times 0.2 \times (v^2 + 1) = \frac{1}{2} \times \frac{1}{2} \times 0.2 \times (9 + 1)$	A1	1.1b
	CLM parallel to line of centres:	M1	3.1a
	$0.3 \times 4 - 0.2 \times 3 = 0.2v - 0.3u \quad (6 = 2v - 3u)$	A1	1.1b
	Impact law parallel to line of centres	M1	3.1a
	$v + u = e(4 + 3)$	A1	1.1b
	Solve for $\mathbf{v}_P$ , $\mathbf{v}_Q$ or $e$	M1	1.1b
	$\mathbf{v}_P = \frac{2}{3}\mathbf{i} + 2\mathbf{j} \text{ (ms}^{-1}\text{)} \quad \text{and} \quad \mathbf{v}_Q = 2\mathbf{i} + \mathbf{j} \text{ (ms}^{-1}\text{)}$	A1	1.1b
	$e = \frac{4}{21}$	A1	1.1b
	$v = -2 \Rightarrow u = -\frac{10}{3} \Rightarrow P \text{ and } Q \text{ have passed through each other: impossible, so solution is unique} \quad *$	A1*	2.4
		(11)	
<b>(b)</b>	Use trig to find angle between velocities	M1	3.1a
	$\cos \theta = \left( \frac{\frac{8}{3} + 4}{\sqrt{20}\sqrt{4\frac{4}{9}}} \right) \quad \text{or} \quad \theta = \tan^{-1} \frac{2}{\frac{2}{3}} - \tan^{-1} \frac{1}{2}$	A1ft	1.1b
	$\theta = 45^\circ \left( \frac{\pi}{4} \text{ rads} \right)$	A1	1.1b
		(3)	
<b>(14 marks)</b>			
<b>Notes:</b>			

<b>(a)B1</b>	Seen or implied. Correct only
<b>M1</b>	Equation for KE of $Q$ . Dimensionally correct. Condone $\frac{1}{2}$ on the wrong side.
<b>A1</b>	Correct unsimplified equation in $v^2$
<b>M1</b>	Equation for CLM. Correct terms required. Condone sign errors. Dimensionally correct.
<b>A1</b>	Correct unsimplified equation
<b>M1</b>	Correct use of impact law. Condone sign errors
<b>A1</b>	Correct unsimplified equation.
<b>M1</b>	Complete method to solve for $\mathbf{v}_p, \mathbf{v}_q$ or $e$
	(Working in $e$ gives $v = \frac{1}{5}(6 + 21e)$ and $441e^2 + 252e - 64 = 0$ )
<b>A1</b>	Both velocities correct. Need to see answers in the form $a\mathbf{i} + b\mathbf{j}$ or equivalent
<b>A1</b>	Correct only. 0.19 or better (0.19047....)
<b>A1*</b>	Or equivalent justification of given result. e.g. a negative value for $e$ is not possible
<b>(b) M1</b>	Use of trig or equivalent to find a relevant angle between two velocities e.g by scalar product or difference between angles.
<b>A1ft</b>	Correct unsimplified equation in $\theta$ . Follow their $\mathbf{v}_p$
<b>A1</b>	Correct only. (0.785... radians) Do not ISW

Question	Scheme	Marks	AOs
<b>6(a)</b>	Work done against friction = $3l \times \mu mg \cos \theta$ $\left( = \frac{9mgl}{13} \right)$	B1	3.4
	Gain in EPE = $\frac{kmg \times 4l^2}{2l}$ $(= 2kmgl)$	B1	3.4
	Gain in GPE = $mg \times 3l \sin \theta$ $\left( = \frac{15mgl}{13} \right)$	B1	3.4
	Work energy equation:	M1	2.1
	$\frac{1}{2}m \times 6gl = \frac{9mgl}{13} + 2kmgl + \frac{15mgl}{13}$	A1	1.1b
	$2k = 3 - \frac{24}{13} = \frac{15}{13}, \quad k = \frac{15}{26} \quad *$	A1*	2.2a
		<b>(6)</b>	
<b>(b)</b>	Tension in the string at B: $\frac{\frac{15}{26}mg \times 2l}{l}$ $\left( = \frac{15mg}{13} \right)$	B1	3.1a
	Equation of motion: tension + component of weight – friction = $ma$	M1	3.3
	$\frac{15mg}{13} + mg \sin \theta - \frac{1}{4}mg \cos \theta = ma$ $\left( mg \left( \frac{15}{13} + \frac{5}{13} - \frac{3}{13} \right) = ma \right)$	A1 A1	1.1b 1.1b
	$a = \frac{17g}{13}$	A1	1.1b
		<b>(5)</b>	
<b>(11 marks)</b>			
<b>Notes:</b>			
<b>(a)B1</b>	Use model to obtain one correct term		
<b>B1</b>	Use model to obtain two correct terms		
<b>B1</b>	Use model to obtain three correct terms		
<b>M1</b>	Work-energy equation. Need all terms and no extras. Dimensionally correct. Condone sign errors and sin/cos confusion.		
<b>A1</b>	Correct unsimplified equation		
<b>A1*</b>	Obtain given result from correct working		
	NB: The use of <i>suvat</i> equations is not a valid alternative method because the acceleration is not constant		
<b>(b) B1</b>	Correct unsimplified expression for the tension in the string		

<b>M1</b>	Equation of motion. Need all terms and no extras. Condone sign errors and sin/cos confusion Allow with $T$ or their $T$
<b>A1</b>	Unsimplified equation with at most one error
<b>A1</b>	Correct unsimplified equation
<b>A1</b>	Exact answer or accept 12.8 or 13 ( $\text{ms}^{-2}$ )

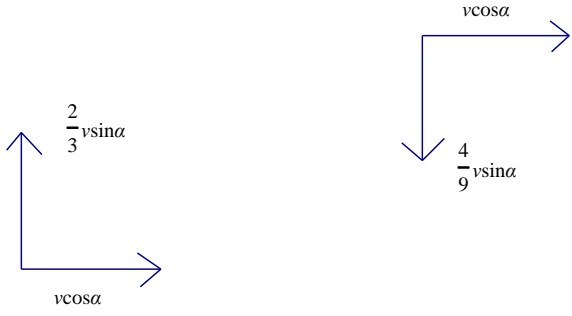
Question	Scheme	Marks	AOs
<b>7(a)</b>	Use model to find components of velocity after the impacts:  	B1	3.1b
		B1	3.4
		B1	3.1b
		B1	3.4
	$\tan \frac{\alpha}{2} = \frac{\frac{4}{9}v \sin \alpha}{v \cos \alpha} \left( = \frac{4}{9} \tan \alpha \right)$	M1	3.1b
	$t = \tan \frac{\alpha}{2} \Rightarrow t = \frac{4 \times 2t}{9(1-t^2)}$	M1	1.1b
	$1-t^2 = \frac{8}{9}, \quad t = \frac{1}{3} *$	A1*	2.2a
		<b>(7)</b>	
<b>(b)</b>	$\tan \alpha = \frac{\frac{2}{3}}{1 - \frac{1}{9}} = \frac{3}{4}$	B1	1.1b
	change in KE $\frac{1}{2}mv^2 - \frac{1}{2}m \left( v^2 \cos^2 \alpha + \left( \frac{4}{9}v \right)^2 \sin^2 \alpha \right)$	M1	3.1b
	% of KE lost = $100 \left( 1 - \frac{\frac{1}{2}mv^2 \left( \frac{16}{25} + \frac{16}{81} \times \frac{9}{25} \right)}{\frac{1}{2}mv^2} \right)$	M1	1.1b
	$= 28.888...(\%)$	A1	1.1b
		<b>(4)</b>	
<b>(11 marks)</b>			
<b>Notes:</b>			
<b>(a)B1</b> <b>B1</b> <b>B1</b> <b>B1</b>	One mark for each component correct.		
<b>M1</b>	Form expression for $\tan \frac{\alpha}{2}$ in terms of $\tan \alpha$		

<b>M1</b>	Form and solve equation in $\tan \frac{\alpha}{2}$
<b>A1*</b>	Obtain given answer from correct working
	<b>NB: This is a “Show that ..” question. A candidate who assumes, without proof, that <math>\tan \frac{\alpha}{2} = e^2 \tan \alpha</math> can only score the last two marks.</b>
<b>(b)B1</b>	Correct use of $t = \frac{1}{3}$ Must be seen / used in part (b)
<b>M1</b>	Dimensionally correct expression for change in KE NB note that they may not show component parallel to the wall
<b>M1</b>	Dimensionally correct expression for the percentage of KE lost.
<b>A1</b>	Accept 29(%) or better Accept $\frac{260}{9}$